

# Hyperbolic Theory: Homoclinic Tangle and Horseshoe

## 1. Smale's Horseshoe

### A. *Some simple geometric terms*

- For a 2-d vector  $\tau = (u, v)$ , let  $s(\tau) = \frac{|v|}{|u|}$  be the *slope* for  $\tau$ .

- For  $\gamma < \frac{1}{2}$ ,

$$\mathcal{C}_h = \{\tau : s(\tau) \leq \gamma\}$$

is the horizontal cone of size  $\gamma$ , and

$$\mathcal{C}_v = \{\tau : s(\tau) > \gamma^{-1}\}$$

is the vertical cone of size  $\gamma$ . We let  $\gamma$  be fixed throughout this lecture.

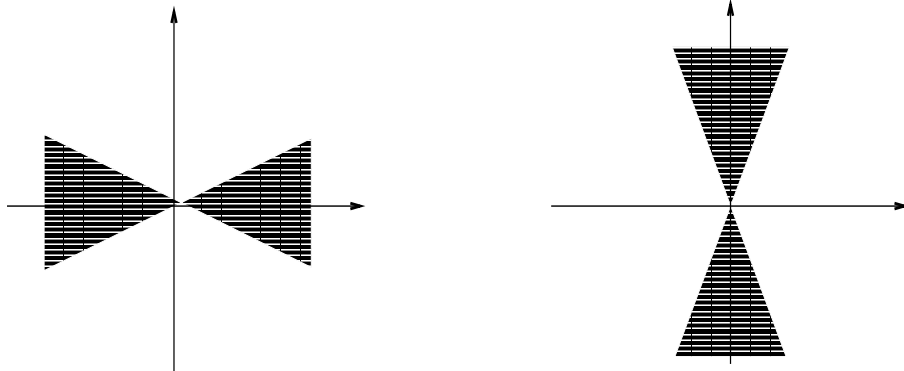

- Let  $D = [0, 1] \times [0, 1]$  be the unit square in  $\mathbb{R}^2$ . Associated to every point  $z \in D$  is a 2-dimensional tangent space, therefore a horizontal and a vertical cone of size  $\gamma$  at  $z$ .
- Let  $l : I \rightarrow D$  be a smooth curve parameterized by curve length. For  $z \in l$  let  $\tau(z)$  be the tangent vector of  $l$  at  $z$ . We call  $l$  a *horizontal segment* if  $\tau(z) \in \mathcal{C}_h$  for all  $z \in l$ . Similarly,  $l$  is a *vertical segment* if  $\tau(z) \in \mathcal{C}_v$  for all  $z \in l$ .

Note that a horizontal segment and a vertical segment can only intersect at most at one point.

- For  $z = (x, y) \in D$  let  $\pi_1(z) = x, \pi_2(z) = y$ . A horizontal segment is  $h$ -crossing if  $\pi_1 \circ l = [0, 1]$ . Similarly, a vertical segment is  $v$ -crossing if  $\pi_2 \circ l = [0, 1]$ .

- We call a connected region  $R \subset D$  a *regular square* if it is bounded by two non-intersecting horizontal segments and two non-intersecting vertical segments.

We call a regular square  $H$  a *horizontal strip* if the two horizontal segments bounding  $H$  are both  $h$ -crossing. Similarly, a regular square  $V$  is a *vertical strip* if the vertical boundaries of  $V$  are both  $v$ -crossing.

- Let  $H$  be a horizontal strip bounded by  $l_1, l_2 : [0, 1] \rightarrow D$ . The height of  $H$  is defined as  $\max_{x \in [0, 1]} \{|l_1(x) - l_2(x)|\}$ .

The width of a vertical strip is defined similarly.

## B. The horseshoe map

Let  $T : D \rightarrow \mathbb{R}^2$  be  $C^1$  and assume that

**(H1)** There exist vertical stripes  $V_1, V_2$  and horizontal strips  $H_1, H_2$  in  $D$  such that  $T(V_1) = H_1, T(V_2) = H_2$ .

**(H2)** Let  $\mathcal{C}_h(z, \gamma)$  be the horizontal cone of size  $\gamma$  at  $z \in V_1 \cup V_2$ . We have

$$DT_z(\mathcal{C}_h(z, \gamma)) \subset \mathcal{C}_h(T(z), \gamma).$$

Furthermore, there exists  $\lambda > 2$  such that

$$|DT_z \tau| > \lambda |\tau|, \quad \forall \tau \in \mathcal{C}_h(z, \gamma).$$

**(H3)**  $T : (V_1 \cup V_2) \rightarrow (H_1 \cup H_2)$  is a diffeomorphism and  $T^{-1} : H_1 \cup H_2 \rightarrow V_1 \cup V_2$  satisfies the following invariant cone condition parallel to (H2): Let  $\mathcal{C}_v(z, \gamma)$  be the vertical cone of size  $\gamma$  at  $z \in H_1 \cup H_2$ . We have

$$DT_z^{-1}(\mathcal{C}_v(z, \gamma)) \subset \mathcal{C}_v(T^{-1}(z), \gamma).$$

We further have

$$|DT_z^{-1} \tau| > \lambda |\tau|, \quad \forall \tau \in \mathcal{C}_v(z, \gamma).$$

Let  $V = V_1 \cup V_2$ ,  $H = H_1 \cup H_2$ . For  $n > 0$  let

$$\Lambda = \bigcap_{n=-\infty}^{\infty} T^n V.$$

$\Lambda$  is the set of points in  $V$  that stays forever inside of  $V$  under the forward and backward iterations of  $T$ . Inheriting the 2-d distances in  $D$ ,  $\Lambda$  is a metric space and  $(\Lambda, T)$  is a well-defined dynamical system.

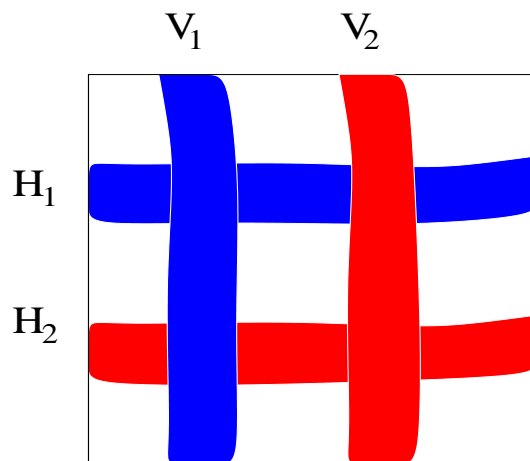

### C. *Full-shift of two symbols*

Let

$$\Sigma_2 = \{(\cdots s_{-1}s_0, s_1, \cdots) : s_i \in \{1, 2\}\}$$

be the space of bi-infinite sequences of two symbols. For  $s, t \in \Sigma_2$  where  $s = \{s_i\}$ ,  $t = \{t_i\}$ ,

let

$$d(s, t) = \sum_{i=0}^{\infty} \frac{|s_i - t_i| + |s_{-i} - t_{-i}|}{4^n}$$

to make  $\Sigma_2$  a metric space.

Let  $\sigma : \Sigma_2 \rightarrow \Sigma_2$  be such that

$$\sigma(\cdots s_{-1}s_0, s_1, \cdots) = (\cdots s_{-1}s_0s_1, s_2, \cdots)$$

$(\Sigma_2, \sigma)$  is a dynamical system, which we call the *full-shift of two symbols*.

**Theorem**  $(\Lambda, T)$  is topologically conjugate to  $(\Sigma_2, \sigma)$ . i.e., there exists a homeomorphism  $h : \Lambda \rightarrow \Sigma_2$  such that  $h \circ T = \sigma \circ h$ .

**Proof:** Let us make the following observations:

(a) Let  $l$  be a horizontal segment in  $V$  and  $|l|$  its length. Then  $T(l)$  is also a horizontal

segment and  $|T(l)| > \lambda|l|$ . This is from (H2). Similarly, if  $l$  is a vertical segment in  $H$ , then  $T^{-1}l$  is also a vertical segment and  $|T^{-1}l| > \lambda|l|$  from (H3).

(b) Let  $V^{(n)}$  be the set in  $V$  such that  $T^i V \subset V$  for all  $i < n$ . Then  $V^{(n)}$  is a collection of vertical stripes, each of which we denote as  $S^{(n)}$  in  $V$ . In addition,  $T^n(S^{(n)})$  is a horizontal strip.

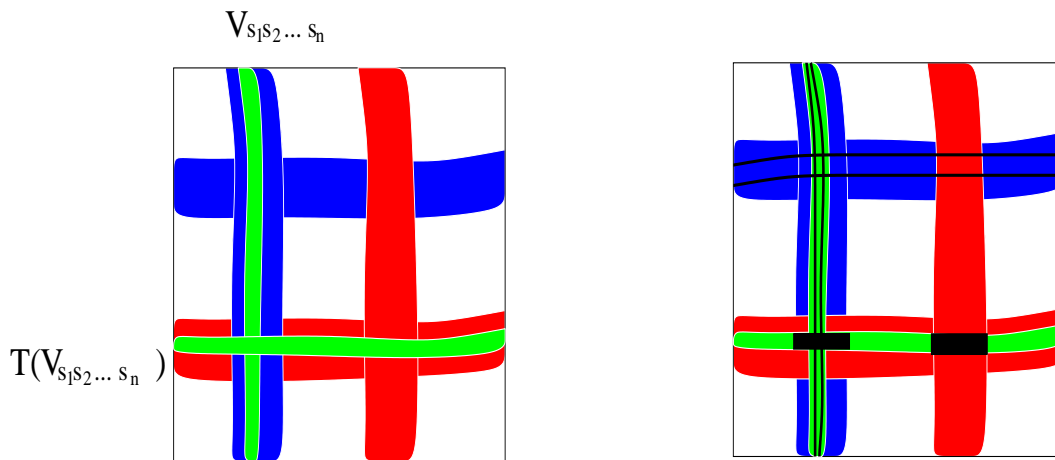

This is easily proved by induction: assume inductively that  $V^{(n)}$  is as described. Let  $S_1^{(n+1)} := T^{-n}(T^n(S^{(n)}) \cap V_1)$ ,  $S_2^{(n+1)} := T^{-n}(T^n(S^{(n)}) \cap V_2)$ , both are vertical strips

in  $S^{(n)}$ . Note that for  $z \in S^{(n)}$ ,  $T^n z \in V$  if and only if  $z \in (S_1^{(n+1)} \cup S_2^{(n+1)})$ . Hence

$$V^{(n+1)} = \cup_{S^{(n)} \in V^{(n)}} \{S_1^{(n+1)}, S_2^{(n+1)}\}.$$

It is also clear that

$$T^{n+1}(S_1^{(n+1)}) = T(T^n(S^{(n)}) \cap V_1)$$

is a horizontal strip in  $H_1$ . Similarly

$$T^{n+1}(S_2^{(n+1)}) = T(T^n(S^{(n)}) \cap V_2)$$

is a horizontal strip in  $H_2$ .

(c) We also claim that, for every sequence  $t_1 t_2 \cdots t_n$  of  $\{1, 2\}$  of length  $n$ , there exists a **unique** component  $S \in V^{(n)}$ , such that

$$S \subset V_{t_1}, T(S) \subset H_{t_1}, T^2(S) \subset H_{t_2}, \cdots, T^n(S) \subset H_{t_n}$$

and  $T^n(S)$  is a horizontal strip in  $H_{t_n}$ .

This is again proved by induction: Assume that  $S^{(n)}$  be the vertical strip in  $V^{(n)}$  corresponding to the sequence

$$t_1 \cdots t_n.$$

Then  $S_1^{(n+1)}$  in the above corresponds to

$$t_1 \cdots t_n 1$$

and  $S_2^{(n+1)}$  in the above corresponds to

$$t_1 \cdots t_n 2.$$

Let us denote the component in  $V^{(n)}$  corresponding to  $t_1, \dots, t_n$  as  $V_{t_1 \dots t_n}$ .

(d) We now simply replace  $V$  by  $H$ ,  $T$  by  $T^{-1}$  in the above. Parallel to (b) and (c), we conclude that  $H^{(n)}$ , the set of all  $z \in H$  such that  $T^{-i}z \in H$ ,  $i < n$ , is a collection of horizontal strips. Furthermore, for any given sequence  $\hat{t}_1 \dots \hat{t}_n$  of  $\{1, 2\}$  of length  $n$ , there exists a unique component  $S \in H^{(n)}$ , such that

$$S \subset H_{\hat{t}_1}, T^{-1}(S) \subset V_{\hat{t}_1}, \dots, T^{-n}(S) \subset V_{\hat{t}_n}.$$

Let us denote the component in  $H^{(n)}$  corresponding to  $\hat{t}_1 \dots \hat{t}_n$  as  $H_{\hat{t}_1 \dots \hat{t}_n}$ .

(e) Let

$$s_{-n} \dots s_{-1} s_0, s_1 \dots s_n$$

be a sequence of  $\{1, 2\}$  of size  $2n + 1$  centered at  $s_0$ . Then

$$T^{n+1}(V_{s_{-n} s_{-(n-1)} \dots s_0})$$

is a horizontal strip height  $< \lambda^{-(n+1)}$ . Similarly

$$T^{-n}(H_{s_n s_{n-1} \dots s_1})$$

is a vertical strip of width  $< \lambda^{-n}$ . Let

$$D_n = T^{(n+1)}(V_{s_{-n}s_{-(n-1)}\dots s_0}) \cap T^{-n}(H_{s_n s_{n-1}\dots s_1}).$$

$D_n$  is a regular square of size  $< 2\lambda^{-n}$ .

**Remarks:** (i) For  $z \in T^{n+1}(V_{s_{-n}\dots s_{-1}s_0})$  we have that under the forward iteration of  $T$ ,

$$\begin{array}{ccccccc} T^{-n}z & \rightarrow & \dots & \rightarrow & T^{-1}z & \rightarrow & z \\ \in H_{s_{-n}} & \rightarrow & \dots & \rightarrow & \in H_{s_{-1}} & \rightarrow & \in H_{s_0} \end{array} \quad (1)$$

Note that because of the unique correspondence between the symbolic sequences of length  $n$  and the connected components of  $V^{(n)}$ , the reverse is also true: that if (1) holds for  $z$  then  $z \in T^{n+1}(V_{s_{-n}\dots s_{-1}s_0})$ .

(ii) For  $z \in T^{-n}(H_{s_n\dots s_1})$ , we have that under the iteration of  $T^{-1}$

$$\begin{array}{ccccccc} T^{n-1}z & \rightarrow & \dots & \rightarrow & Tz & \rightarrow & z \\ \in V_{s_n} & & \dots & & \in V_{s_2} & \rightarrow & \in V_{s_1} \end{array}$$

Reverse under the iteration of  $T$  and recall that  $T(V_i) = H_i$ , we obtain

$$\begin{array}{ccccccc} z & \rightarrow & Tz & \rightarrow & \dots & \rightarrow & T^{n-1}z \\ \in V_{s_1} & \rightarrow & \in H_{s_1} & \rightarrow & \dots & \rightarrow & \in H_{s_{n-1}} \end{array} \quad (2)$$

Again by the uniqueness of the corresponding symbolic sequences the connected components of  $H^{(n)}$ , we have that if (2) hold for  $z$  then  $z \in T^{-n}(H_{s_n\dots s_1s_0})$ .

(iii) So for  $\mathbf{z} \in D_n$ , we have

$$\begin{array}{ccccccc} z_{-n} & \cdots & z_{-1} & \mathbf{z}, & z_1 & \cdots & z_{n-1} \\ \in H_{s_{-n}} & \cdots & \in H_{s_{-1}} & \in (V_{s_1} \cap H_{s_0}); & \in H_{s_1} & \cdots & \in H_{s_{n-1}} \end{array}$$

(f) Let  $a(z) = i$  be the address of  $z$  for  $z \in H_i$ . We defined  $h : \Lambda \rightarrow \Sigma_2$  as follows. For  $z_0 \in \Lambda$ , let

$$h(z_0) = (\cdots s_{-n} \cdots s_{-1} s_0, s_1, \cdots s_n \cdots)$$

where  $s_i = a(T^i(z_0))$ ,  $i \in \mathbb{Z}$ .

**Claim 1.1**  $h : \Lambda \rightarrow \Sigma_2$  as in the above is a homeomorphism satisfying

$$h \circ T = \sigma \circ h.$$

**Proof:**  $h$  is surjective: For

$$s = (\cdots s_{-(n-1)} \cdots s_0, s_1 \cdots s_n \cdots) \in \Sigma_2,$$

let

$$p := \bigcap_{n=1}^{\infty} D_n \in \Lambda.$$

It is by definition that  $h(p) = s$ .

**$h$  is 1-1:** If  $h(z) = s$  for

$$s = (\cdots s_{-(n-1)} \cdots s_0, s_1 \cdots s_n \cdots) \in \Sigma_2,$$

then  $z \in D_n$  for all  $n$ . This is because all  $z$  satisfying (2) is in  $T^{-(n+1)}(H_{s_n \cdots s_1 s_0})$  and all  $z$  satisfying (1) is in  $T^{(n+1)}(V_{s_{-n} \cdots s_{-1} s_0})$ . Therefore  $z = \bigcap_n D_n$ .

**$h$  is continuous:** Let  $n$  be fixed we have only finitely many ( $2^{2n+1}$  to be precise) non-intersecting regular squares  $D_n$ . Let  $\varepsilon_n$  be the smallest of the distances between any two of these regular squares.

Let  $p_1, p_2 \in \Lambda$  be such that  $|p_1 - p_2| < \varepsilon$  and assume that  $\varepsilon < \varepsilon_m$  for some  $m > 0$ , then  $p_1, p_2$  must be in the same  $D_m$  hence  $d(h(p_1), h(p_2)) < 2^{-m}$ . So  $h$  is continuous.

We can also prove that  $h^{-1}$  is continuous.

**$h$  is a conjugate:** We need to prove  $h \circ T = \sigma \circ h$ . Let  $z_0 \in \Lambda$  be such that

$$h(z_0) = (\cdots s_{-n} \cdots s_0, s_1 \cdots s_n \cdots).$$

Then

$$h(z_1) = (\cdots s_{-n} \cdots s_0 s_1, \cdots s_n \cdots).$$

is the coding for  $z_1 = T(z_0)$ . Observe that the right hand is  $\sigma(h(z_0))$  and the left hand is  $h(T(z_0))$ .

## 2. Homoclinic Tangle and Chaos

### A. *The inclination lemma*

Let  $U$  be a small neighborhood in  $\mathbb{R}^2$  around  $(0, 0)$ , and  $T : \mathbb{R}^2 \rightarrow \mathbb{R}^2$  be defined on  $U$  by

$$x_1 = \lambda x + \alpha(x, y)x, \quad y_1 = \mu y + \beta(x, y)y.$$

We assume that there exists a constant  $C$  such that for all  $z = (x, y) \in U$ ,

$$|\alpha(z)|, |\beta(z)| < C|z|;$$

$$|\partial_x \alpha(z)|, |\partial_y \alpha(z)|, |\partial_x \beta(z)|, |\partial_y \beta(z)| < C.$$

In what follows  $K > 0$  is arbitrarily given, and we let  $n_1 > 0$  be the smallest such that

$$\lambda^{-n_1} K C \ll \lambda - 1.$$

Also, for  $K > 0$  given we denote

$$U_1(K) = \{z \in U : T^i z \in U, \quad i \leq n_1\}$$

**Proposition** (The inclination lemma) For  $K, \varepsilon > 0$  given, there exists  $n_0$  sufficiently large, such that for all  $z \in U$  satisfying  $T^i z \in U_1(K), \forall i \leq n_0$ ,

$$DT^{n_0}(\mathcal{C}(z, K)) \subset \mathcal{C}(T^{n_0}z, \varepsilon)$$

where  $\mathcal{C}(z, K)$  stands for the horizontal cone of size  $K$  at  $z$ .

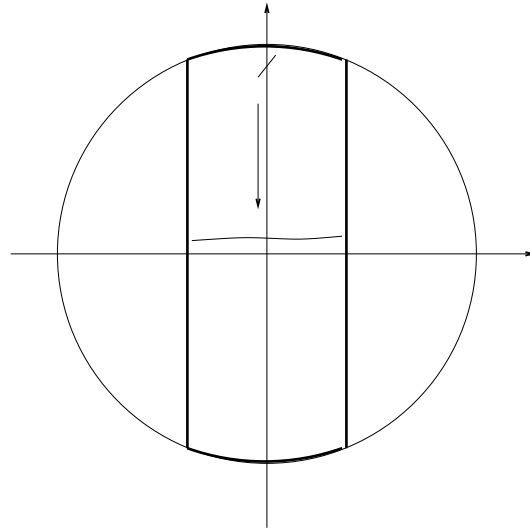

**Proof:** For  $\tau = (u, v)$ , a tangent vector at  $z = (x, y) \in U_1(K)$ , let  $\tau_1 = (u_1, v_1) = DT_z \tau$ . We have

$$\begin{aligned} u_1 &= (\lambda + \alpha(z) + x\partial_x\alpha(z))u + x\partial_y\alpha(z)v \\ v_1 &= y\partial_x\beta(z)u + (\mu + \beta(z) + y\partial_x\beta(z))v. \end{aligned}$$

Let  $s(\tau)$  be the slope of  $\tau$ , we have

$$s(\tau_1) \leq \frac{|y\partial_x\beta(z)| + |(\mu + \beta(z) + y\partial_x\beta(z))|s(\tau)}{|(\lambda + \alpha(z) + x\partial_x\alpha(z))| - |x\partial_y\alpha(z)|s(\tau)}$$

Observe that by the way  $n_1$  is defined we have

$$|x\partial_y\alpha(z)s(\tau)| \ll |\lambda| - 1.$$

This is because we must have  $1 > |x_n| > \lambda^{n_1}|x|$  so

$$|x\partial_y\alpha(z)K| < KC\lambda^{-n_1} \ll \lambda - 1.$$

So for  $z \in U_1(K)$  and  $\tau \in \mathcal{C}(z, K)$ , we have

$$s(\tau_1) \leq (\hat{\lambda})^{-1}(Cy + \hat{\mu}s(\tau))$$

where  $\hat{\mu} < 1$  is slightly larger than  $|\mu|$ .

For  $z \in U$ ,  $\tau \in \mathcal{C}(z, K)$  satisfying the assumptions of this proposition, let  $z_i = T^i z$ ,  $\tau_i = DT_z^i \tau$ . We have that, for  $i \leq n_0$ ,  $z_i \in U_1(K)$ . So

$$s(\tau_i) \leq \hat{\lambda}^{-1}(Cy_{i-1} + \hat{\mu}s(\tau_{i-1})).$$

Inductively using the last estimate we obtain

$$s(\tau_{n_0}) < \sum_{i=1}^{n_0} C\hat{\lambda}^{-i}|y_{n_0-i}| + \hat{\lambda}^{-n_0}s(\tau) < (Cn_0 + K)\rho^{n_0} < \varepsilon$$

where  $\rho = \max(\hat{\lambda}^{-1}, \hat{\mu}) < 1$ .

**Remark:** Let  $(x, y) = (0, 0)$  be a saddle point of a smooth mapping  $T : \mathbb{R}^2 \rightarrow \mathbb{R}^2$ . By a linear coordinate change we write  $T$  as

$$x_1 = \lambda x + \alpha(x, y), \quad y_1 = \mu y + \beta(x, y)$$

where  $|\lambda| > 1 > |\mu|$ , and  $\alpha(x, y)$  are higher order terms in  $(x, y)$ . According to the existence theorem on the local stable and unstable manifolds, we have in a small neighborhood  $U$  of  $(0, 0)$ ,  $\phi(x)$  and  $\psi(y)$ , such that

$$W^u = \{(x, \phi(x))\} \cap U, \quad W^s = \{(\psi(y), y)\} \cap U$$

Since  $W^u, W^s$  are tangent to  $x$  and  $y$ -axis respectively, we have

$$\phi'(0) = 0, \quad \psi'(0) = 0.$$

We now introduce coordinate change  $(x, y) \rightarrow (x - \psi(y), y - \phi(x))$ . This coordinate change makes the  $x$ -axis the local unstable manifold in  $U$  and the  $y$ -axis the stable manifold for  $T$ . So in a sufficiently small neighborhood  $U$  of the fixed point  $(0, 0)$ , from the fact that both the  $x$  and  $y$ -axis are  $T$ -invariant, we can write  $T$  as

$$x_1 = \lambda x + \alpha(x, y)x, \quad y_1 = \mu y + \beta(x, y)y.$$

Also, we can shrink the size of  $U$  properly such that

$$|\alpha(x, y)|, |\beta(x, y)| < C|(x, y)|.$$

We can also assume that all the partial derivatives of  $\alpha$  and  $\beta$  are also bounded by  $C$ .

These are exactly what were assumed for  $T$  in the inclination lemma.

## B. Homoclinic Tangles

Let  $z_0$  be a hyperbolic fixed point as in the above. Then in a small neighborhood  $U$  of  $z_0$ , **local** stable and unstable manifold, which we now write as  $W_{loc}^u$  and  $W_{loc}^s$  are two well defined smooth curves.

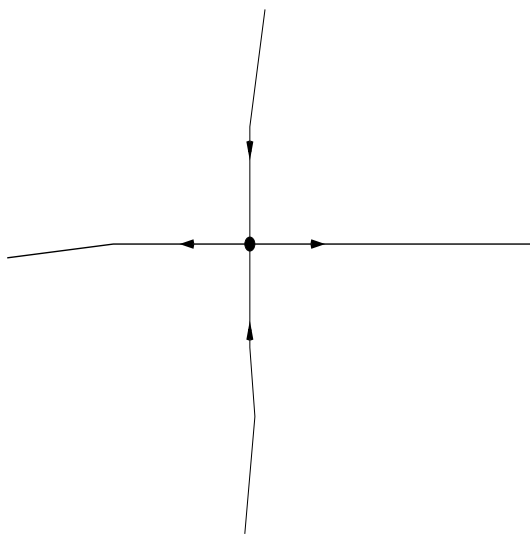

Under the iterations of  $T$ ,  $W_{loc}^s$  converges to  $z_0$ . So is  $W_{loc}^u$  under the iterations of  $T^{-1}$ .

**Question:** What happens when we iterate  $W_{loc}^s$  using  $T^{-1}$ ? Similarly, how about iterating  $W_{loc}^u$  using  $T$ .

**Answer:** We simply extend these local curves out of  $U$ . What happens to these curves depend completely on the properties of  $T$  away from  $z_0$ .

We call

$$W^u(z_0) = \bigcup_{n>0} T^n W_{loc}^u$$

the global stable manifold of  $z_0$  (Under the backward iterations of  $T$ , all points on  $W^u(z_0)$  convergence towards  $z_0$ ).

Similarly, we define

$$W^s(z_0) = \cup_{n>0} T^{-n} W_{loc}^s$$

as the global stable manifold of  $z_0$  (Under the forward iterations of  $T$ , all points on  $W^u(z_0)$  converges towards  $z_0$ ).

We now consider the case in which  $W^u(z_0)$  and  $W^s(z_0)$  intersecting at a point  $p$ , which we call a **homoclinic point**. We call the orbit of  $p$  a **homoclinic orbit**. If the intersection at  $p$  is not tangential, we call  $p$  a **transversal homoclinic point**.

Then following the inclination lemma we derive the following picture (homoclinic tangle) if we have a transversal homoclinic intersection.

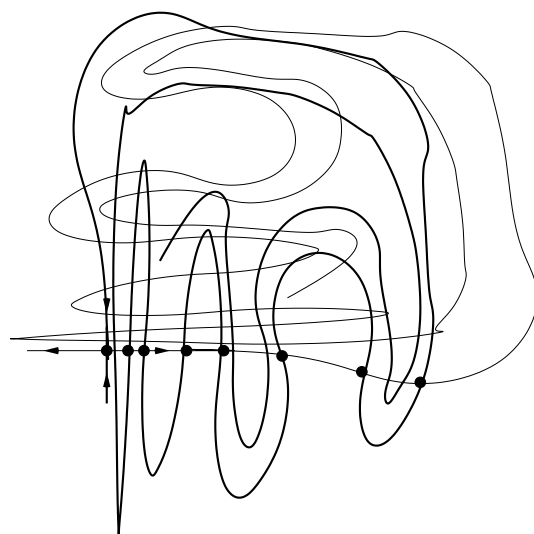

### C. Horseshoe maps in homoclinic tangles

Let  $T : \mathbb{R}^2 \rightarrow \mathbb{R}^2$  be  $C^2$ -diff, and  $z_0$  is such that  $z_0 = T(z_0)$ . Let  $\lambda$  and  $\mu$  be the eigenvalues of  $DT_{z_0}$ . Under the assumption that  $|\lambda| > 1 > |\mu|$ , the stable manifold  $W^s(z_0)$  and the unstable manifold  $W^u(z_0)$  are well-defined. We assume that  $W^u(z_0) \cap W^s(z_0) \neq \emptyset$ .

Let  $p \in W^u(z_0) \cap W^s(z_0)$  be a transversal homoclinic point.

**Theorem** Let  $T$  be as in the above and assume that there exists a transversal homoclinic point  $p \in W^u(z_0) \cap W^s(z_0)$ . Then there exists an integer  $n_0$  sufficiently large, and a compact subset  $\Lambda \subset \mathbb{R}^2$  that is  $T^{n_0}$ -invariant, such that  $(\Lambda, T^{n_0})$  is topologically conjugate to  $(\Sigma_2, \sigma)$ .

**Proof:** As usual, let us first move the center of the coordinate system to  $(0,0)$  and write

the map  $T$  in a small neighborhood  $U$  of  $(0,0)$  as

$$x_1 = \lambda x + \alpha(x, y)x, \quad y_1 = \mu y + \beta(x, y)y.$$

Then the  $x$ -axis in  $U$  is the local unstable manifold and the  $y$ -axis is the stable manifold. The inclination lemma applies to  $T$ .

**Step 1:** Let us argue that inside  $U$  we can take a square  $R := [-a, a] \times [-a, a]$  for some  $a > 0$ , such that the following holds:

(i) There is a point  $p \in R$  on the  $y$ -axis that is a transversal homoclinic point. Since  $p$  is on the unstable manifold, there exists an  $N_0$ , and a point  $q$  on the  $x$ -axis in  $R$  such that  $T^{N_0}q = p$ .

(ii) Let us further take a small segment  $I_x$  on the  $x$ -axis around  $q$ , such that  $l := T^{N_0}I_x$ , a piece of unstable manifold passing  $p$ , is a horizontal segment inside of  $R$ . Let us assume that

the slope of all tangent vectors of  $l$  is smaller than, say,  $\frac{1}{100}$ .

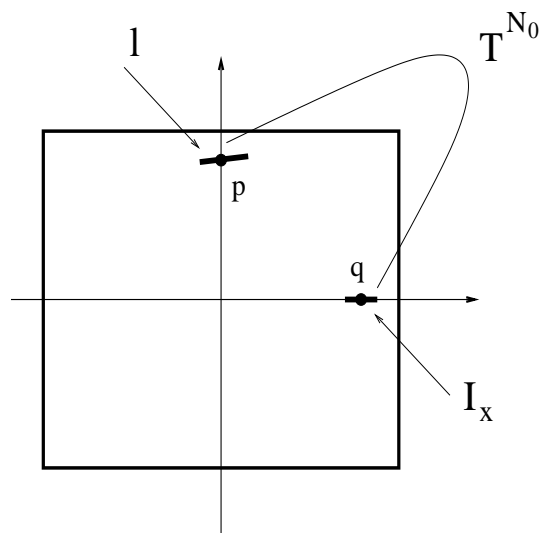

To obtain this picture we reason as follows: By assumption we know that there is a transversal homoclinic point, which we denote as  $p'$ . The images of  $p'$  under the forward iterations of  $T$  will eventually enter  $U$  because  $p'$  is on  $W^s(z_0)$ . Denote this images as  $p''$ . The unstable manifold intersects the  $y$ -axis at  $p''$ , and by assumption this intersection is non-tangential. Therefore there is a small piece of the unstable manifold around  $p''$  such that the slopes of all the tangent vectors on this piece is bounded away from the vertical direction. By using the inclination lemma, the forward images of a sub-segment around  $p''$  can be as horizontal as we wish. Here we require that the slope of all tangent vectors of an images be  $< \frac{1}{100}$ . Let  $p$  be the corresponding image

of  $p''$ , and draw a square  $R$  to cover  $p$  and a small piece of the unstable manifold around  $p$ .

**Step 2** For  $n$  sufficiently large, let  $D_n$  be bounded by the  $x$ -axis, the  $y$ -axis, the line  $y = a$  and a vertical curve we call  $l_n$ , which is defined as follows: Let  $x^{(n)}$  be the largest  $x > 0$  such that  $T^i(x, a) \in R, 0 < i \leq n$ . We have  $T^n(x^{(n)}, a) = (a, y^{(n)})$  for some  $y^{(n)} > 0$ . We let  $l_n := \{T^{-n}(a, y), 0 \leq y \leq y^{(n)}\}$ .

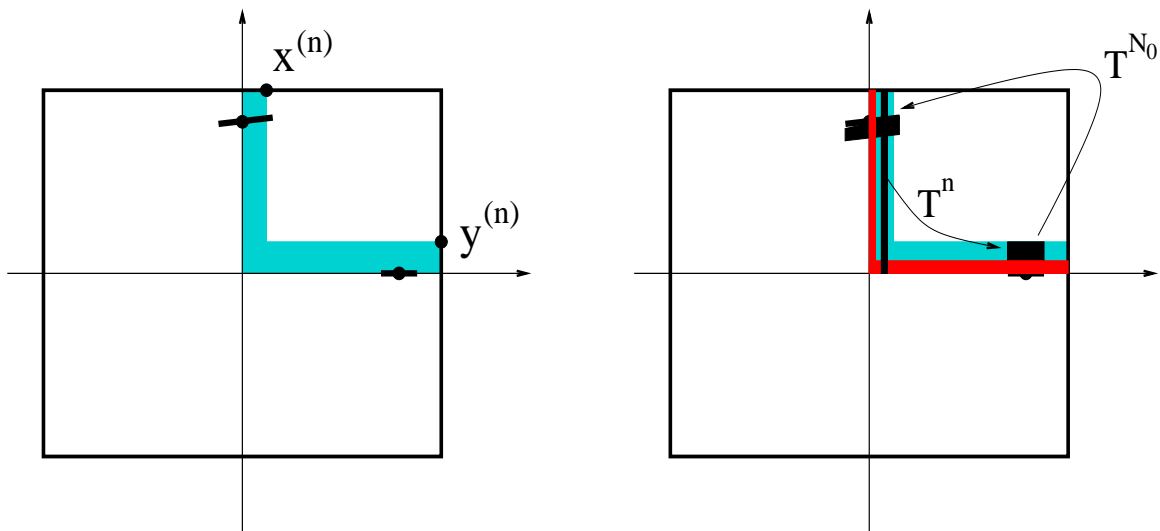

Assume that  $n \gg N_0$ . In  $D_n$  we define  $H_1, V_1$  and  $H_2, V_2$  as follows:

(1)  $H_1 := D_n \cap T^n(D_{n+N_0})$ ,  $V_1 := T^{-(n+N_0)}H_1$ ;

(2) Let  $I_x$  be as in Step 1(ii), and

$$\mathcal{H} := \{z \in T^n(D_n) : \pi_1(z) \in I_x\}$$

. We let

$$H_2 := T^{N_0}\mathcal{H} \cap D_n, \quad V_2 := T^{-N_0-n}H_2$$

To prove this Theorem it suffices for us to check (H1)-(H3).

**Proof of (H1)** It is clear by the inclination lemma that  $H_1$  is a horizontal strip in  $D_n$ . That  $V_1$  is a vertical strip in  $D_n$  follows from applying the inclination lemma to  $T^{-1}$ .

$H_2$  is a horizontal strip in  $D_n$  because one of its horizontal boundaries is  $l \cap D_n$  where  $l$  is as in Step 1(ii), and the other boundary is as  $C^1$ -close to the first one as we wish. This is because, by letting  $n$  sufficiently large, we can make the horizontal boundaries of  $\mathcal{H}$  as  $C^1$ -close as we want. We make them so close that applying  $T^{N_0}$  does not make a difference simple by continuity.

Note that the vertical boundaries of  $T^{-N_0}H_2$  are not necessarily vertical curves. However, by applying the inclination lemma to  $T^{-1}$ , we know that  $V_2$  is a vertical strip by assuming that  $n$  is sufficiently large.

Let  $n_0 := n + N_0$ . This far we prove that (H1) for the horseshoe map holds for  $T^{n_0}$  on  $D_n$ .

**Proof of (H2)** Let us assume that  $\gamma > \frac{1}{10}$ . First for  $z \in V_1$  and  $\tau \in \mathcal{C}(z, \gamma)$ .  $DT_z^{n_0}\tau \in \mathcal{C}(T^{n_0}(z), \gamma)$  trivially follow from the inclination lemma. We also have

$$|DT_z^{n_0}\tau| > (\hat{\lambda})^{n_0}|\tau|.$$

So (H2) holds on  $V_1$ .

For  $z \in V_2$ , and  $\tau \in \mathcal{C}(z, \gamma)$ , we have  $T^n z \in \mathcal{H}$  and  $s(DT_z^n \tau) < \varepsilon$ . We can make  $\varepsilon$  as small as we wish by making  $n$  larger. Let  $\tau_n := DT_z^n \tau$ . Let  $\hat{z} := (\pi_1(z_n), 0)$ . Then  $s(DT_{z_n}^{N_0} \tau_n)$  can be arbitrarily close to  $s(\hat{z}_{N_0})$ , which is by assumption  $< \frac{1}{100} \ll \gamma$ . Therefore

$$DT_z^{n_0} \tau \in \mathcal{C}(z_{n_0}, \frac{1}{100} + K^{N_0} \varepsilon) \subset \mathcal{C}(z_{n_0}, \gamma).$$

For the expanding property we see that

$$|\tau_n| > (\hat{\lambda})^n |\tau|$$

This increase in size is not going to be un-done by applying  $DT^{N_0}$ .

**Proof of (H3):** We apply the same argument to  $T^{-n_0}$ .